



PRO GUIDE

/ TEQUILA6

CONTENT

1	Introduction	3
2	Description	4
3	Technical Data	5
4	Line System	5
5	Acceleration System	6
6	Flight Techniques and Characteristics	7
7	Descent Techniques	7
8	Materials	8
9	Homologation	9
10	Closing Words	10
11	Line Schematic	11
12	Line Length	11
13	Risers	12
14	Overview Glider	13
15	Test Protocol	14



1 INTRODUCTION

Welcome to skywalk!

Congratulations on the purchase of your new TEQUILA6 and thank you for your trust in us and in our products. In this manual you will find product-specific information that will help you quickly get to know your new paraglider to ensure your fun for a long time. General information about the most important safety-relevant points for handling your paraglider can be found in the attached „BASIC GUIDE“.

We are always open for questions, comments or critique and are happy to provide you at any time with further information!

Your skywalk Team
PURE PASSION FOR FLYING

Edition 1.0 / 07_23
The latest version of the manual can be found on
www.skywalk.info

2 DESCRIPTION

The TEQUILA6 is our sporty entrance into the B-class. The simple flight behavior in combination with the sporty handling and an accessible performance result in a particularly well-balanced wing.

The concept is rounded off with a high level of passive safety.

PILOT REQUIREMENTS

The TEQUILA6's high level of performance and its forgiving handling make it suitable from occasional pilots to ambitious thermal flyers and XC pilots.

SCOPE OF DELIVERY

The TEQUILA6 comes standard with inner bag, compression strap, riser bag and "BASIC GUIDE".



3 TECHNICAL DATA

Size	75	85	95	105	115	135
Cell number	49	49	49	49	49	49
Area flat (m ²)	21,50	23,45	24,97	26,54	28,29	30,67
Wingspan flat (m)	10,60	11,07	11,42	11,77	12,16	12,66
Aspect ratio flat	5,22	5,22	5,22	5,22	5,22	5,22
Area projected (m ²)	18,41	20,09	21,39	22,73	24,23	26,27
Wingspan projected (m)	8,48	8,86	9,14	9,43	9,73	10,13
Aspect ratio projected	3,91	3,91	3,91	3,91	3,91	3,91
min. profile depth (cm)	76	80	82	85	87	91
max. profile depth (cm)	251	262	270	279	288	300
Middle line length without risers (m)	6,66	6,96	7,18	7,40	7,64	7,96
Line consumption (m)	230	241	249	257	266	277
Weight (kg)	4,6	4,8	5	5,3	5,6	5,8
Take-off weight, certified from-to (kg)	55-75	65-85	75-95	85-105	95-115	105-135
Winch certified	yes	yes	yes	yes	yes	yes
JET FLAP Technology	yes	yes	yes	yes	yes	yes
Paramotor homologation	no	no	no	no	no	no
Accelerator	yes	yes	yes	yes	yes	yes
Maximum speed bar travel (mm)	160	160	180	180	180	180
Brake line travel max. (cm)	57	59	62	65	68	70
Trimmers	no	no	no	no	no	no
Number of seats	1	1	1	1	1	1

4 LINE SYSTEM

The layout of the suspension points is designed for optimal load distribution and a long lifespan. With all considerations and calculations however, our focus is always on safety. The mix of materials used on the lines of the TEQUILA6 is an ideal combination of durability, low stretch and low drag.

The skywalk TEQUILA6 has 3 A-, 3 B-, 3 C-, and 1 stabilo line. The main-stabilo is connected with the B-riser. The brake lines are not load-bearing and lead from the trailing edge over the main brake lines through the brake pulleys on the C-risers to the brake handles. A marking on the main brake line indicates the position of the handle attachment. This setting should not be lengthened, for example, to provide more brake travel in extreme flight situations or during landing, nor shortened such that the glider is flown constantly with some brake on.

To provide a better overview and to make sorting easier, the lines have different colors:

- the A1, AII, AIII-main lines and the A-risers are red.
- the B1, BII, BIII-main lines are yellow.
- the C1, CII, CIII-main lines are blue.
- the main stabilo lines are orange.
- the brake lines are orange.

The lines are attached with loops to oval shackles and secured with plastic inserts.

The skywalk TEQUILA6 has 4 risers per side:

- the two inner A-mainlines lead to the A1-riser, the outer A-line leads to the A2-riser.
- the B-lines as well as the stabilo lines lead to the B-riser.
- the C-lines lead to the C-riser.

A schematic drawing of the risers can be found on page 12.

5 ACCELERATION SYSTEM

The skywalk TEQUILA6 can be equipped with a foot-operated acceleration system. The acceleration system effects the A1-, A2- and B-risers. Exact lengths of the accelerated risers can be found on page 12.

Any other adjustable, removable or variable devices are not available



6 FLIGHT TECHNIQUES AND CHARACTERISTICS

WINCHTOWING

The skywalk TEQUILA6 is well suited for winch towing. Make sure that you only use certified winches and that you climb from the ground at a flat angle.

The pilot must have had proper towing instruction and must ensure that the winch operator has had proper training that includes paragliders. When launching on a winch, always fly with a lot of feeling and don't brake too much as your glider will already have an increased angle of attack. We recommend the use of a towing adapter.

FLYING WITH A MOTOR

Currently, the TEQUILA6 has no certification for flying with a motor. You can find out the current status of motor certification at any dealer or importer, or by asking skywalk directly.

You can find further information on practices and characteristics of flying in the enclosed „BASIC GUIDE“.

7 DESCENT TECHNIQUES

BIG EARS

In contrast to the spiral dive, with big ears your forward speed is higher than your sink speed. This descent method is used to quickly leave dangerous areas in a desired horizontal direction. The danger of canopy disturbances in turbulent air is greatly reduced with big ears. Proceed as follows (according to DHV teaching instructions):

- Step on the speed bar half-way, grab the outer A-lines, which are suspended on separate A-risers, below the line shackles with your palms facing outward and pull the lines down.
- Now press the speed bar all the way. Keep the brake handles and the outer A-lines in your hands during the maneuver.
- Check the symmetry of the collapsed glider.
- To recover, slowly release the A-lines. The glider usually will reinflate by itself.
- As soon as the glider is fully open, release the speed bar.
- To speed up reinflation, pull lightly on the brakes. Another proven technique is to first reinflate one side of the glider, then the other. This can reduce the risk of a stall.

Examples:

- If the pilot is surprised near a summit with little ground clearance by strong wind or a thundercloud, neither a B-stall nor a spiral dive can help.
- If the pilot is stuck in very strong lift, it is advisable to exit the lift band with the use of big ears and to find sinking air in which to lose altitude.

B-LINE STALL

The B-lines are pulled down symmetrically 15-20cm. Keep the brake handles in the respective hands. The airflow on top of the profile largely detaches and the paraglider descends without flying forward. Pulling hard on the B-risers allows you to decrease the area of the wing and increase your sink rate, but this also increases the risk of the wing forming a rosette to the front. If this happens, recovery from the B-stall immediately! You can exit the stall by quick and symmetric release of the B-lines. The paraglider will pitch forward and pick up speed. At no time you may use the brakes in this case!

You can find further information about descent techniques in the enclosed "BASIC GUIDE".

8 MATERIALS

The skywalk TEQUILA6 is manufactured from the highest quality materials. skywalk has selected the best possible combination of materials with regard to resilience, performance and longevity. We are aware that the durability of the glider is a deciding factor in the pilot's satisfaction. Spare parts can be obtained from skywalk.

WINGS AND RIBS

Upper sail: Myungjin MJ40 MF 40g
 Lower sail: Myungjin MJ32 MF 32g
 Ribs: Porcher Skytex 40g hard

LINES

A, B, C Main lines: Liros PPSLS 180/125
 A, B, C Middle lines: Liros PPSLS 125/65
 A, B, C, D Top lines: Liros DC 60
 Brake lines: Liros DFLP 200/32, PPSL 125/65

RISERS

Güth & Wolf 12mm webbing

PULLEYS

Ronstan ball bearing

SHACKLES

Jootech oval

9 HOMOLOGATION

The TEQUILA6 is certified to LTF II 91/09 and EN926-1, EN926-2 in the category B. The TEQUILA6 is defined as a lightweight sport aircraft with an empty weight of less than 120kg in the paraglider category. The many homologation tests are the last hurdle in the development of a skywalk paraglider. The homologation test flights only take place when the test team is completely happy with the glider development.

We remark that the certification results will differ during flight in thermals or turbulent air. The homologation informs solely regarding the paraglider performance during extreme-flight-maneuvers performed in stable air conditions. These extreme-flight-maneuvers during the homologation process should thus not be over-valued.

Remember that certification maneuvers were carried out with a harness in the group GH with a carabiner distance (middle to middle) of 40-48 cm. If another harness is used, the glider may display flight characteristics that differ from those in the description.

HARNESS MEASUREMENTS DURING THE TEST FLIGHTS

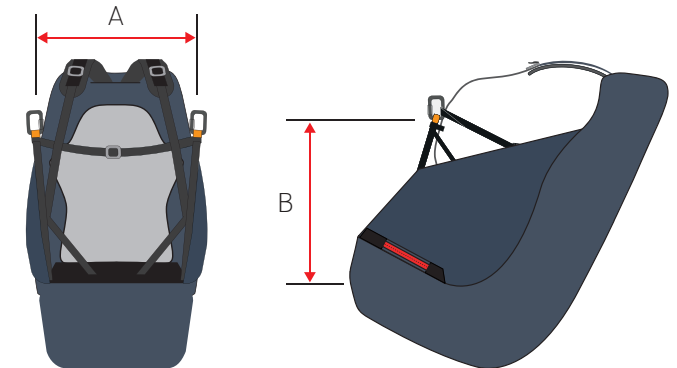

Width of harness attachment points

Height of harness attachment points

Total weight in flight (kg)	< 80	80-100	> 100
Width (cm-measurement ‚A‘)	40 ± 2	44 ± 2	48 ± 2
Height (cm-measurement ‚B‘)	40 ± 1	42 ± 1	44 ± 1

10 CLOSING WORDS

The skywalk TEQUILA6 is at the pinnacle of paraglider development in the market for intermediate gliders and shows what is possible regarding performance, safety and innovation.

It cost us a lot of time to develop this glider, but it was also a lot of fun. In this development we recognize the challenge of making the right product for every area and individual taste. We are pleased if you notice this during your first flight and if you feel a certain unity with your glider from the very beginning.

The TEQUILA6 will provide you with plenty of joy over many years if you treat it and care for it properly. Respect for the demands and dangers of our sport are essential for successful and beautiful flights.

Even the safest paraglider can be dangerous due to misjudgments of meteorological conditions or pilot error. Always remember that flying sports are potentially risky and that you are responsible for your own safety. We advise you to fly carefully and to respect laws in the interest of our sport, because every pilot always flies at his or her own risk!

WE WISH YOU A LOT OF FUN WITH YOUR NEW GLIDER AND ALWAYS HAPPY LANDINGS!!

Your skywalk Team



11 LINE SCHEMATIC

This line schematic is only for illustration purposes.

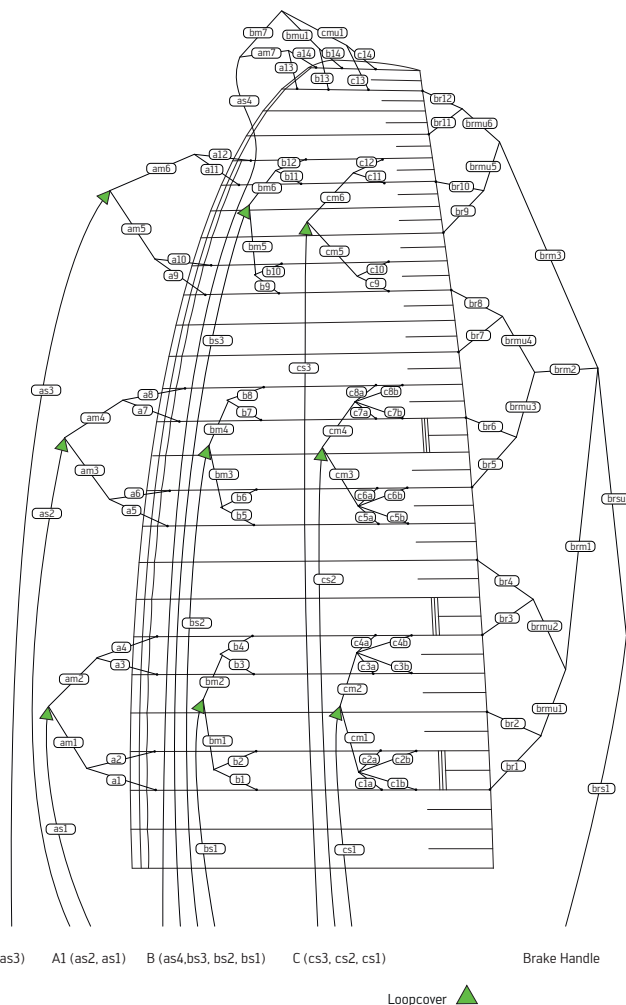

12 LINE LENGTH

The total line length has to be measured under a tension of 50N. The difference between the measured length and the original length should not exceed $\pm 10\text{mm}$. Compliance of the test sample's suspension lines, brake lines and risers were checked by the testing laboratory after the test flights were completed.

Total line length and single line length TEQUILA6 size 75, 85, 95, 105, 115 and 135:

www.skywalk.info

13 RISERS

The difference between the measured riser lengths and the original riser lengths should not exceed ± 5 mm.

TEQUILA6, size 75 and 85:

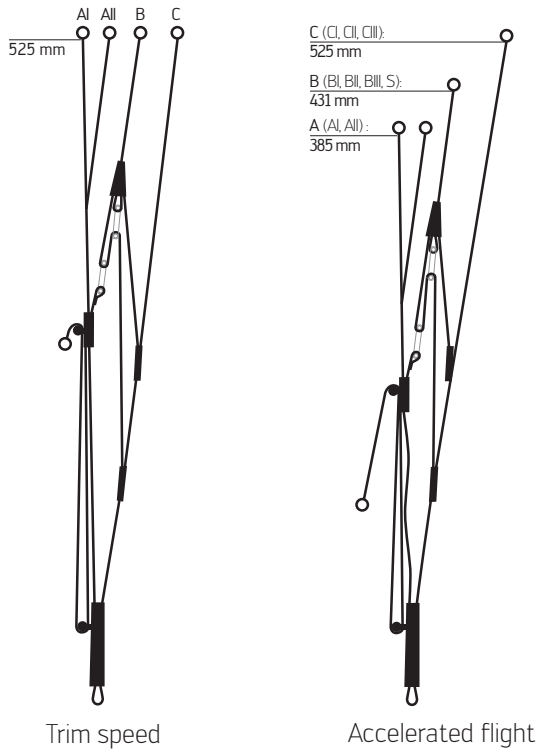

TEQUILA6, size 95, 105, 115 and 135:

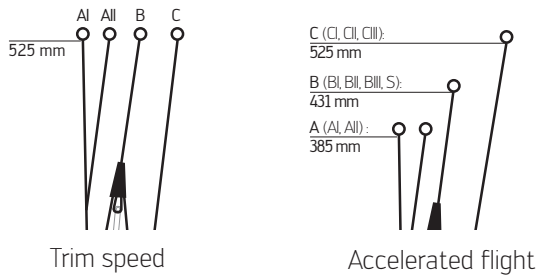

14 OVERVIEW GLIDER



15 TEST PROTOCOL			Date:
Customer, Name:			
Adress:		Phone:	
Glider:	Size:	Serial number:	
Type certificate number:		Date of last check:	
Date of first flight:		Year of construction:	

Accomplished checking:	Results [+/-]:	Description of failure:	Suggested repairs:
Identification:	<input type="checkbox"/> + <input type="checkbox"/> -		
Visual check of canopy:			
Upper surface:	<input type="checkbox"/> + <input type="checkbox"/> -		
Lower surface:	<input type="checkbox"/> + <input type="checkbox"/> -		
Profiles:	<input type="checkbox"/> + <input type="checkbox"/> -		
Line flares:	<input type="checkbox"/> + <input type="checkbox"/> -		
Leading edge:	<input type="checkbox"/> + <input type="checkbox"/> -		
Trailing edge:	<input type="checkbox"/> + <input type="checkbox"/> -		
Crossports:	<input type="checkbox"/> + <input type="checkbox"/> -		
Visual check of lines:			
Seams:	<input type="checkbox"/> + <input type="checkbox"/> -		
Abrasion spots:	<input type="checkbox"/> + <input type="checkbox"/> -		
Core withdrawals:	<input type="checkbox"/> + <input type="checkbox"/> -		
Visual check of connectionparts:			
Suspension line screw locks:	<input type="checkbox"/> + <input type="checkbox"/> -		
Risers:	<input type="checkbox"/> + <input type="checkbox"/> -		
Length measurement:			
Risers:	<input type="checkbox"/> + <input type="checkbox"/> -		
Lines:	<input type="checkbox"/> + <input type="checkbox"/> -		
Examinations of the canopy:			
Firmness of canopy:	<input type="checkbox"/> + <input type="checkbox"/> -		
Porosity:	<input type="checkbox"/> + <input type="checkbox"/> -		

Examinations of the lines:			
Firmness of main lines: <input type="checkbox"/> <input type="checkbox"/> <input type="checkbox"/> <input type="checkbox"/> <input type="checkbox"/> daN			
	Results [+/-]:	Description of failure:	Suggested repairs:
Visual check of trimming:	<input type="checkbox"/> + <input type="checkbox"/> -		
Checkflight necessary?	<input type="checkbox"/> + <input type="checkbox"/> -		
Type certificate patch?	<input type="checkbox"/> + <input type="checkbox"/> -		
Identification plate?	<input type="checkbox"/> + <input type="checkbox"/> -		
Condition: <input type="checkbox"/> New			
<input type="checkbox"/> Very good condition			
<input type="checkbox"/> Good condition			
<input type="checkbox"/> Well used			
<input type="checkbox"/> Heavily used, but within homologation standards, frequent checks required			
<input type="checkbox"/> No longer airworthy, outside of the limit values.			
Repairs made?:			
Signature of tester:		Date:	
Name of tester:		Firm stamp:	

Skywalk GmbH & Co. KG

Windeckstr. 4 | 83250 Marquartstein

+49 (0) 8641/69 48 0

info@skywalk.org | www.skywalk.info

SKYWALK

   PURE PASSION FOR FLYING